

# Antique Yukimi Lantern



## Ornament and Tradition | Historical context for enduring design

The temples and shrines of Japan used lanterns made in bronze, iron, and stone to hold votive candles as a decorative, spiritual, and symbolic element in these sacred spaces as early as 6th Century AD. These traditional lanterns weren't meant to provide functional light for pathways, but as the Japanese tea ceremony started to develop in the 16th Century AD, they were borrowed and placed in the garden for ambiance and reference to transcendence. Most sources agree that the evolution of the stone garden lantern design resulted from tea masters seeking elements for the environment where they would practice.

## Beauty and Design | Styles and Types of Stone Lanterns

–Yukimi-gata | Snow-Viewing Lanterns: Elegant with open legs and wide roofs that are usually round or hexagonal in shape. Usually placed “near water elements”, and “so named because of the delicate way they hold snow on the roof.” This Stone Forest lantern is inspired by this.

### Care for the wood windows:

Please note that wood breathes, expands and contracts. Each wood window will respond differently to changes in temperature and humidity. Expansion at the joints and seams is to be expected as the seasons change and some minor checking may also result. Maintenance consists of the occasional application of a paste wax containing carnauba.

Here is an example of a wood conditioning product: [Sunshield Wood Conditioner](https://www.howardproducts.com/product/sunshield-wood-conditioner/) (https://www.howardproducts.com/product/sunshield-wood-conditioner/)

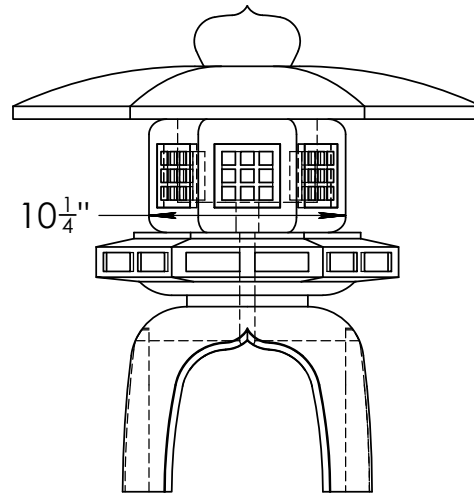
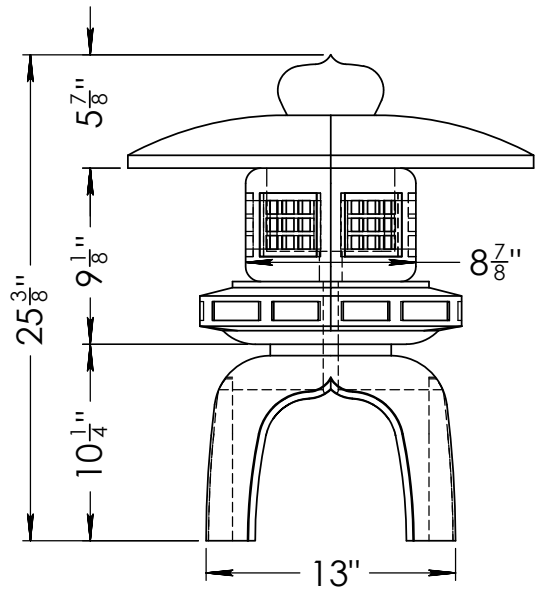
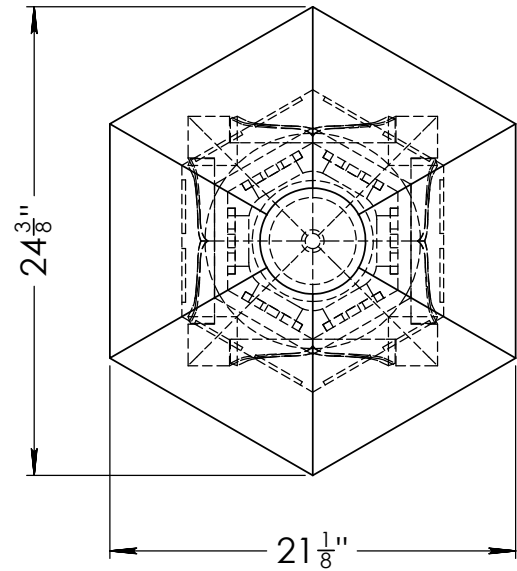

Antique Yukimi  
NL09-24A

Due to the hand-carving of each piece, small variances in shape and size are to be expected.

SIZE **A** DWG. NO. L09-24A

REV. **A**

WEIGHT: SHEET 1 OF 1

©2022 Stone Forest, Inc.

DO NOT SCALE DRAWING